

VEI Systems Installation Instructions

D1-FPP-PYC-Mx – Dual Pyrometer / Exhaust Gas Temperature Gauge (deg-C)

D1-FPP-PYF-Mx – Dual Pyrometer / Exhaust Gas Temperature Gauge (deg-F)

Please read these instructions completely before beginning installation to ensure that you have the tools and skills necessary for installation and operation of this instrument. If you are not sure that you can perform the installation safely, then consult a qualified installer. Further instructions available at www.VEISystems.com/technical.html.

MOUNTING

Install the unit through the front of the mounting hole in the dash pod or panel. If you are making a custom dash panel, you will need to drill a 2-1/16" hole. Slide the clamp onto the 2 studs on the back of the instrument. Secure with the 2 thumb-nuts. Use a small drop of threadlocker or nail polish on the thumb-nuts to prevent them from loosening under vibration.

For fuel-pressure, use sender SEN-F100 or SEN-P100F. Mount the sender onto the fuel system in an appropriate location. Generally, you would need to connect to the fuel-rail near the injectors. In most cases, there will be a fuel-pressure test-port at that point. You can also use the test port with an appropriate adapter. Avoid using teflon tape or compound as this may eventually break off and get into the fuel stream, causing blockage in the fuel lines. This can be catastrophic to the engine. If you experience leaks, try tape only on the back half of the threads on the sender. The engine must be well grounded to the chassis & battery.

Use two of exhaust-gas temperature probe with integrated controller SEN-TCI or use one of dual exhaust-gas temperature probe with integrated controller SEN-TCI2. This gauge will not work with an exhaust gas temperature probe by itself. Drill and tap the exhaust manifold or header for the 1/8" NPT compression fitting. The best location is close to the exhaust ports on the head, and before the turbocharger if you have one. You will need to do this in two locations for this dual gauge, usually one probe for each exhaust bank. Note that when you drill and tap the exhaust manifold, metal shavings will get into the exhaust and could cause damage to the engine and/or turbocharger, so it is recommended that you remove the manifold/header to clear it out. Screw in the compression fitting into the exhaust manifold and slide the probe through the fitting. The probe should be setup such that the tip is centered in the exhaust stream. You can do this by sliding the probe in and out of the fitting to determine it's full range inside the exhaust tube and positioning it to about the midpoint of that range. Finally, clamp down the compression fitting to lock the probe in place. NOTE: once the compression fitting is tightened, it compresses to shape and should not be re-used. If necessary, the thermocouple probe can be gently bent with a tubing bender, but care should be taken not to break the probe. Route the wires and controller away from the major heat sources under the hood.

WIRING

The wires should be connected as below using crimp-on butt-splice connectors, or soldered and sealed with heat-shrink tubing. Before connecting any wires, you should either disconnect the battery power, or carefully connect the wires in the order shown. If not, you may damage the instrument. Use an existing fuse in the fuse panel, or an external fuse to supply power to the instrument. The D1 series instruments use approx. 130mA of current average. and approx. 210mA maximum, so ensure the fuse is sized appropriately. For a typical 6- or 7-gauge setup, a single 5 Amp fuse is good.

CONTROLLER:

- BLACK -- connect to a solid chassis ground under the hood, or directly to the battery. You may need to expose the metal connection point under the hood by scraping or lightly sanding it. A ring terminal and a screw should work well in most cases.
- RED -- connect this to a source of **switched** +12V power. You can use a switched +12V source under the hood or the same source under the dash as the gauge. See notes for the red wire in the instrument section below.
- PURPLE – this is the output signal of the controller. Connect it to either the white or grey input wire on the gauge, depending on channel.
- ORANGE (on dual-probe/controller only) – this is the second-channel output signal of the controller. Connect it to either the white or grey input wire on the gauge, depending on channel.

INSTRUMENT:

- BLACK -- connect to a solid chassis ground under the dash, or directly to the battery. You may need to expose the metal connection point under the dash by scraping or lightly sanding it. A ring terminal and a screw should work well in most cases.
- RED -- connect this to a source of **switched** +12V power. This will usually be found at or near the ignition switch, and will usually have a relay wired through the ignition switch. An alternate source of this is a switched power line from a nearby light or accessory (radio, etc). If you are unsure that the wire can support the power required for the instrument, then use an external relay.
- GREEN – connect this wire to the positive line (+12V) from the headlight switch. When this line receives a positive voltage, the gauge will use the "park-lights" brightness setting. Alternatively, if setting up a racing-mode display, this can be connected to a separate mode switch (12V or 0V signal).
- WHITE – this is the input for the first display channel. Connect this to the purple or orange output wire from the probe controller, depending on channel.
- GREY – this is the input for the second display channel. Connect this to the purple or orange output wire from the probe controller, depending on channel.

Option 1: One dual-EGT probe / controller

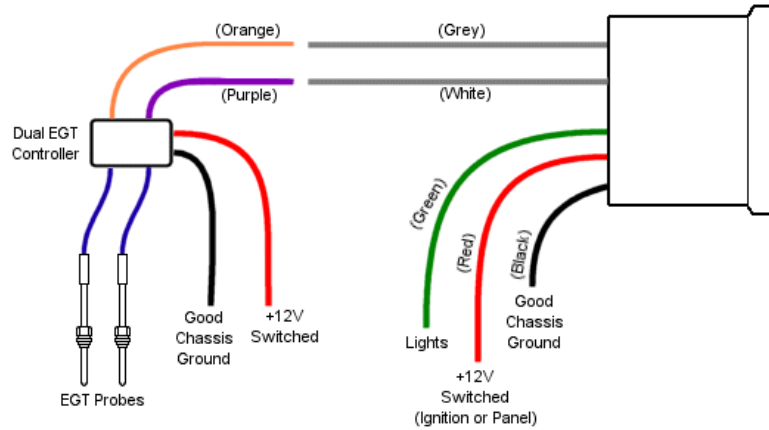

Option 2: Two single-EGT probe / controllers

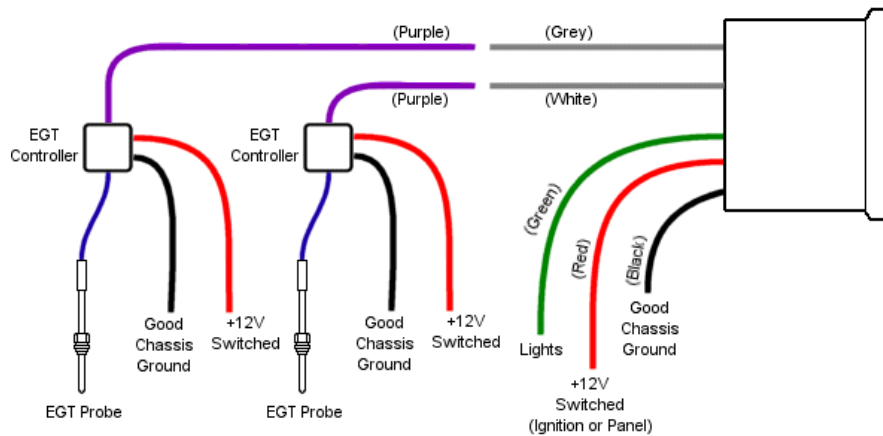

OPERATION

Press and hold the button for a few seconds to change the mode. Press and release quickly (tap the button) to change the setting in any mode. Modes are as follows:

MODE	DISPLAY	SETTINGS
Normal	(Pressure and Temp)	Fuel pressure shown on upper display and exhaust-gas temp on lower display, unless swapped (see next setting below).
Channel swap	Ch1 / Ch2	Allows you to swap the position of the upper & lower displays if required.
Set low fuel-pressure alarm	L . 40	Sets the low fuel-pressure alarm threshold from 1 to 70 PSI.
Set high fuel-pressure alarm	H . 50	Sets the high fuel-pressure alarm threshold from 30 to 99 PSI.
Brightness Regular	Br . 9	Last digit shows regular brightness level from 1 to 9.
Brightness park-lights on	BP . 1	Last digit shows brightness level with lights on from 1 to 9.

WARRANTY & LIABILITY

Neither VEI Systems, nor its dealers or agents shall be liable in any way, for any damage, loss, injury or other claims, resulting from the installation or use of this product. By purchasing or installing this product, you assume all liability of any kind connected with the use and/or application of this product. If you are unsure that you can safely install and use this product, consult a qualified installer or mechanic. The warranty on this product covers only the product itself for a period of 1 year from the date of purchase, and it will be at our discretion to repair or replace the affected parts. No user serviceable parts inside. Warranty void if product enclosure opened.