



## Installation Instructions for Custom Instrument Clusters

Latest update: Jun 30, 2005

Please read these instructions completely before beginning installation to ensure that you have the tools and skills necessary for installation and operation of this instrument. Installation is not difficult, but does take time and some basic knowledge of working on a vehicle. If you are not sure that you can perform the installation safely, then consult a qualified installer. Further instructions available at [www.VEISystems.com/technical.html](http://www.VEISystems.com/technical.html).

### PACKAGE INVENTORY

The first step in the installation procedure should be to verify that nothing is missing from the package – the instrument cluster, senders, connectors, manuals, etc. The included packing list will itemize these for you. If there are any missing items, please contact us immediately, prior to commencing the installation procedure.

### TOOLS & EQUIPMENT

Next, verify that you have the tools and other equipment necessary to perform the installation procedure. You will generally need screwdrivers, pliers, cutters (cutting pliers), a wire stripper, crimper, possibly a soldering iron & solder, wire, wire-connectors, nylon wire-ties, wire-loop, electrical tape, and possibly heat-shrink tubing. You should also have a volt-ohm meter handy to check connections as you go along, as this will save a lot of headaches later. There may be other items required, based on the specifics of the instrument cluster and your vehicle, so it is recommended that you read through the instructions thoroughly prior to commencing the installation procedure.

### PREPARATION

Prior to installation, disconnect the negative battery terminal. Make sure you have any reset codes/procedures necessary for the stereo/alarm or ECU. If available, get a vehicle service manual for your vehicle as this can be very helpful in determining the locations of various components, senders, screw locations, assembly/disassembly procedures, etc.

### SENDERS

The first thing to install are the senders. Most senders depend on the grounding between the engine and chassis for a proper return path, so ensure that the engine is very well grounded. The specifics of this will vary depending on the functions on your cluster, so follow the sections below that are relevant to your cluster:

- ?? **Oil Pressure:** Use the provided sender, which will have a standard 1/8" NPT fitting. Mount this on the engine block on the mounting boss where the original sender or pressure-switch is located. You may use adapters to mount this on a 3/8" or 1/4" NPT boss. You can tee off the existing sender or switch if you need to keep both. Avoid using teflon tape or compound as this may eventually break off and get into the oil stream, causing blockage in the oil passages. This can be catastrophic to the engine. If you experience leaks, try tape only on the back half of the threads on the sender.
- ?? **Water Temperature:** Use the provided sender, which will have a standard 1/8" NPT fitting. Mount this on the engine block on the mounting boss where the original sender or temperature switch is located. You may use adapters to mount this on a 3/8" or 1/4" NPT boss. Here, you will probably need to use teflon tape, so follow the same precautions as for the oil-pressure sender, to prevent clogging any water passages, as this can be catastrophic to the engine.
- ?? **Oil Temperature:** The oil temperature sender is the same as the water-temperature sender, with a standard 1/8" NPT fitting. Mount this on the engine on the existing mounting boss where the original oil-temperature sender or oil-temperature switch is located. Here too, you may use adapters to mount this on a 3/8" or 1/4" NPT boss. Once again, if you need to use teflon tape, follow the same precautions as for the oil-pressure sender, to prevent clogging any oil passages, as this can be catastrophic to the engine. It is recommended that you try this first without any teflon tape.
- ?? **Transmission Fluid Temperature:** The transmission temperature sender is the same as the water-temperature sender, with a standard 1/8" NPT fitting. Mount this on the transmission on the existing mounting boss where the original transmission-temperature sender or transmission-temperature switch is located. If there is no existing sender, you will need to drill a hole for this. The best location for this is usually the transmission oil pan. As with drilling for an oil temperature sender, you will need to completely remove the pan, drill and tap for 1/8" NPT, then clean it thoroughly and re-install. In some cases, you may not have enough thickness to tap the threads, so in these cases, you will need to have a fitting welded/brazed on. Consult a performance automotive shop for this. Here too, you may use adapters to mount this on a 3/8" or 1/4" NPT boss. Once again, if you need to use teflon tape, follow the same precautions as for the oil-pressure sender, to prevent clogging any oil passages, as this can be catastrophic to the engine. It is recommended that you try this first without any teflon tape.
- ?? **Fuel-level:** Usually, you will use the existing fuel-level sender in your vehicle. If we have determined that you need a different sender, you will need to gain access to the top of the tank to replace the sender. This may involve removing the existing fuel tank. Be very careful working around fuel. Absolutely no flames, sparks, smoking, electric tools, etc, and work in a well-ventilated area. Also make sure you have rags and a fire-extinguisher handy just in case. Remove the existing fuel-sender and check the fit of the flange on new sender. If you need to drill any holes, use hand tools or air tools, and take breaks intermittently to avoid any heat build-up. The screw hole pattern is polarized to orient the sender in only one direction. Measure the internal depth of the tank, and cut the sender shaft (not the moveable arm) about an inch shorter than this. Located the sliding arm pivot so that it sits about mid-level in the tank and secure it. Finally, adjust the length of the sliding arm so that at full travel, it would just about be at the top and bottom of the tank.

This will take a bit of trial and error, and may require adjusting the height of the pivot point. Verify that everything fits properly into the tank and that there is clearance inside the tank for the full range of movement of the arm. Now tighten everything properly, as it will be a significant hassle to fix anything later should something come loose. Finally, secure the sender onto the tank using the gasket/seal and existing screws.

- ?? **Speedometer:** If a speedometer sender is provided, you will need to install it by removing the existing speedometer cable from the transmission, and mounting the sender. This can be either a screw-on sender, or a slip-in sender with a securing tab/screw. If the latter, when you remove the original cable assembly, transfer the gear to the new sender before installing it. You do not need to worry about the gear ratio as the speedometer will be calibrated electronically.
- ?? **Tachometer:** There is no sender for the tachometer, but depending on your ignition system, a tach-interface adapter may be provided. Installation of this will be covered in the wiring section.
- ?? **Outside Air Temperature:** The outside air temp sender needs to be mounted in an open space that properly reflects the true outside air temperature. Mounting on a surface that may develop a temperature change due to an engine component is not recommended and in an airstream is also not recommended. A good location is inside the front bumper – free of air flow, and generally free of heat-generating engine components. The rear bumper may also be a good location, but keep it away from exhaust pipes that usually get very hot. You should use nylon wire ties or double-sided sticky tape for this. If using this unit to measure indoor temperature, a good location is between the front seats, perhaps in the console, or behind any of the front seats. The B-pillar (between the front and rear windows) is also a good location. Again, make sure there is no airflow from the airconditioning, direct sunlight heat, or heat coming from the transmission tunnel in that area since this will provide false readings.
- ?? **Gear Position:** The gear position sender measures the travel of the shifter linkage. You can mount this in one of 2 locations – either on or near the transmission, or near the column/tunnel depending on your shifter. Usually the transmission is the easier location, but under the dash is generally more clear of rocks or other road debris. You will need to fabricate a bracket to mount the sender such that the arm travels in-line with the shifter linkage. Connect the sender arm to the shifter linkage using the supplied rod and clevis. Attach the clevis to a central hole on the sender arm, and temporarily hold the other end against the shifter linkage while moving the gear-shift level through all gears, to see the movement/limits of travel of the gear-position sender arm. Adjust from here to get as much travel as possible on the gear-position sender arm. Typically, 135 degrees is very good. When you have determined the best position, mark the rod and make a 90-degree bend at that location. Drill a small hole in the shifter linkage to accommodate the rod, pass the rod through it, and make another 90-degree bend in the rod to secure. You can fine-tune by screwing the clevis in or out. Finally move the gear-shift lever through its full range of motion to ensure that there is no binding. Note: you do not need to worry about the exact sender-arm position for any specific gear position as this will be calibrated electronically later.

## WIRING

Wiring usually instills fear in most people when installing anything electrical in a vehicle, but is not the most difficult – it does take time and can get confusing, but some careful planning will alleviate this. Get a sheet of paper and draw a basic sketch of the components you will be dealing with to lay out a map of the wiring. You will need to show things such as the battery, ignition switch, fuse panel, senders, etc. Also, we assume here the original instrument cluster has already been removed. Or make a copy of the wiring diagram on the next page and write/draw/erase any changes for your specific application.

We are going to wire up the power connections first, then the senders, then the indicators. When we say to connect a wire to the instrument cluster, for now just run the wire to where the instrument cluster will be, but do not connect it to anything. Leave an extra foot or two. This will allow us to easily measure the lengths equally later on, and leave some room so that the back of the cluster can be accessed while the cluster is connected and operating. Actually, on the very first pass, don't wire anything at all – just read through the procedure and draw these on the map, listing the colors and label their function. Then go back through and wire these up in the same sequence, except for the instrument-cluster end, which you can label and tape so they don't fall back through. Finally, when all else is done, connect the remaining hanging wire ends on the dash to the instrument cluster connector. When routing wires through openings, holes, tubes, etc, be careful not to let the wires get cut on any sharp edges.

The following sequence will make the process much easier, with the preferred wire color and thickness shown in parentheses after the wire name. Preferred colors are listed as some of these are industry and will reduce confusion when connecting to the instrument cluster later, or for maintenance later. Since some wires may have the same color, label the ends of the wire as you run each one.

### Power:

- ?? **Ground (black, 16ga):** Connect a wire from a good chassis ground to the instrument cluster. You should clean and lightly sand the area around the ground point before securing the wire. Use a crimp-on wire terminal for a better connection – do not just wrap the wire around a screw. Finally, test the resistance (using an ohmmeter) between this wire and a chassis ground point (not the same point where the wire is connected), to ensure that the connection is very good.
- ?? **Switched positive (red, 16ga):** Connect this to a source of **switched** +12V power. This will usually be found in the fuse panel, at or near the ignition switch, and will usually have a relay wired through the ignition switch. An alternate source of this is a switched power line from a nearby light or accessory (radio, etc). If you are unsure that the wire can supply the power required for the instrument cluster (usually less than 1 Amp), then use an external relay, with the power line coming directly from the battery. This line should also be fused, so ensure that it goes through an appropriate fuse in the fuse panel. Since power consumption is usually less than 1 Amp for the complete cluster, you will not necessarily need to increase the size of the existing fuse. This will also go to the instrument cluster. Test this line and the ground line for approx +12V between them using a voltmeter. (Note that you will need to temporarily re-connect the battery to do this). Turn the ignition key on and off while doing this to verify proper switched operation.

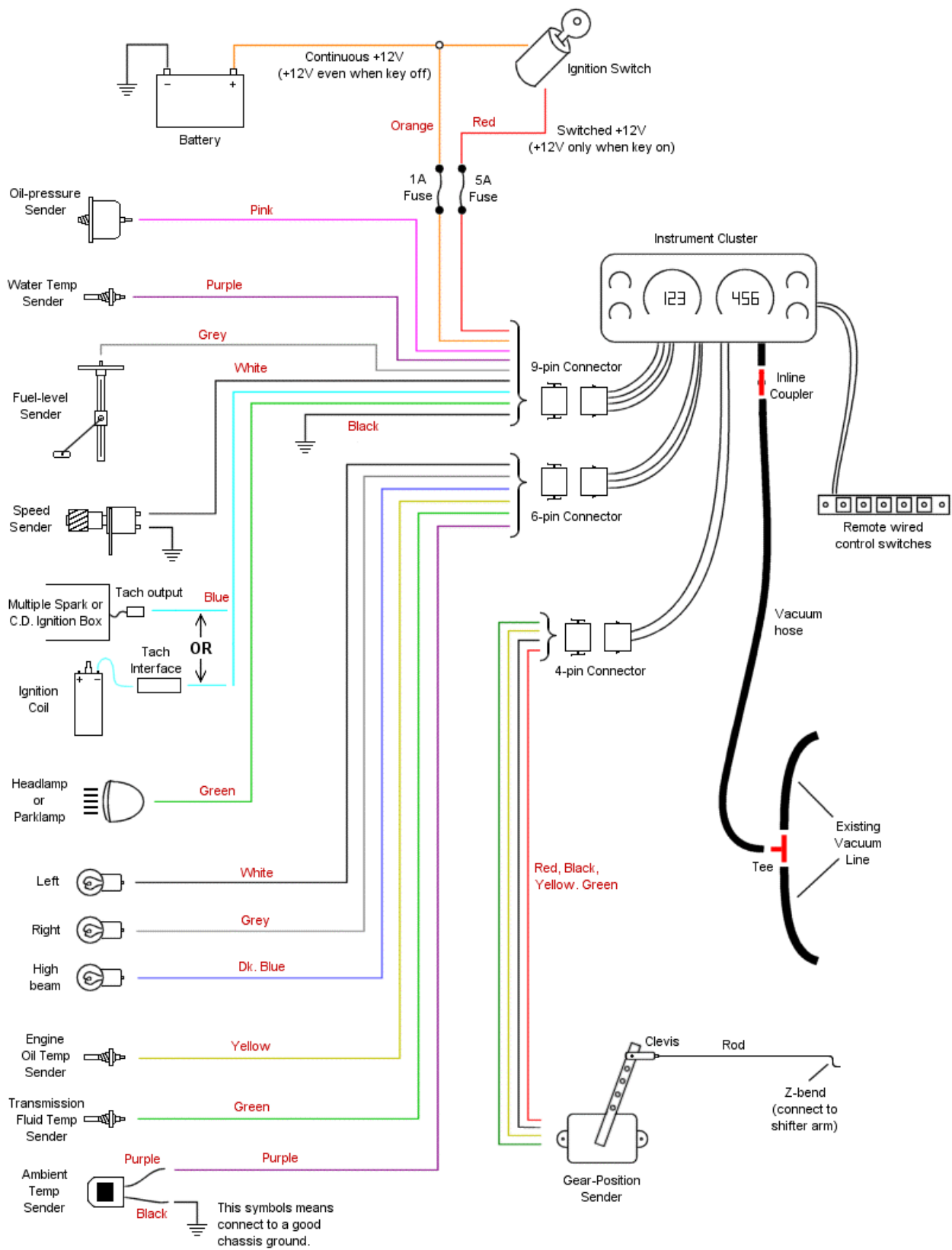

- ?? **Permanent positive (orange, 18ga):** Connect this to a source of constant (key on or off) +12V power, so that the instrument cluster receives power even when the vehicle is off. This is required for the digital clock to keep time. If there is no clock on your instrument cluster, you can skip this step. Power is not required for the instrument cluster to keep its settings. A good source of this is the fuse panel or the battery itself. On the instrument cluster end, test this against the ground wire to ensure proper +12V no matter what the ignition-key position.
- ?? **Lights (green, 18ga):** This signal is a +12V signal that is active whenever the vehicle's park lights or headlights are on. The instrument cluster uses this to dim the display when the lights go on at night. Since each instrument has independently configurable brightness settings for lights off or on, you can wire this to a separate manual switch instead. This will permit custom display settings if you race your vehicle instead of day/night brightness adjustment. Test this wire using a voltmeter against the ground wire to ensure that it provides +12V when the lights (or manual switch) are on, and 0V otherwise.

## Senders:

At this point, with proper power wired up, we'll start wire up the senders following the sequence below. Note that not all of these will be applicable, based on the functions in your instrument cluster.

- ?? **Oil Pressure (pink, 18ga):** For this sender, you will need to run only one wire from the top stud on the sender to the instrument cluster. Note that if you replaced an existing oil-pressure sender or switch, you can re-use the existing wire. You can test this against the ground wire for a resistance of approx 240 ohms or less using an ohmmeter.
- ?? **Water Temperature (purple, 18ga):** The water temperature sender will also be connected with one wire from the top of the stud on the sender to the instrument cluster. Note that if you replaced an existing water-temperature sender or switch, you can re-use the existing wire. Test here for a resistance of a few kilohms or less using an ohmmeter.
- ?? **Oil Temperature (yellow, 18ga):** Like the water temperature sender, this too will also be connected with one wire from the top of the stud on the sender to the instrument cluster. Note that if you replaced an existing oil-temperature sender or switch, you can re-use the existing wire. Test here for a resistance of a few kilohms or less using an ohmmeter.
- ?? **Transmission Fluid Temperature (dark green, 18ga):** The transmission-fluid temperature sender will also be connected with one wire from the top of the stud on the sender to the instrument cluster. Note that if you replaced an existing transmission-fluid temperature sender or switch, you can re-use the existing wire. Test here for a resistance of a few kilo-ohms or less using an ohmmeter.
- ?? **Fuel-level (grey, 18ga):** In most cases, you will use your existing fuel-level sender, and can just re-use the existing wire that goes to the dash. If you do need to re-run a wire, it will be only one wire. Test here against the ground wire for a resistance of 0 to 240 ohms, depending on the sender. If you were not aware of your fuel-level sender resistance range, now is a good time to measure it. See the section on fuel-level gauge operation below for more info.
- ?? **Speedometer (white, 18ga, shielded):** A shielded wire is highly recommended here, though not necessary. This shielded wire will have 1 insulated wire in the center, with a braided shield surrounding it. Connect the center wire from one wire the speedometer sender to the instrument cluster. Connect the other wire on the sender to ground near the transmission. Finally, connect the shield to ground on one end of the wire only (do not connect the shield to anything on the other end of the wire). You cannot test the wire for any specific signal at this point.
- ?? **Tachometer (blue, 18ga, shielded):** As with the speedometer sender, a shielded wire is highly recommended here. If you do not need a tachometer interface, connect this wire from the tach signal (ECU output or tach output from an MSD or similar) to the instrument cluster, and connect the shield to ground on one end of the wire only. Again, do not connect the shield to anything at the other end of the wire. If you are using a tachometer interface, it needs to be mounted near the ignition coil. Connect the red wire on the tach interface to switched +12V (not from the coil!), the black wire to ground (a good chassis ground near the engine), the white wire to the negative of the coil, and the grey wire to the instrument cluster (using the shielded cable). You cannot test this wire for any specific signal at this point.
- ?? **Outside Air Temperature (purple, black, 18ga):** You will need to connect 2 wires for this – a white wire and a black wire. At the instrument cluster end, the white wire will be connected to the instrument cluster, and the black wire will be connected to ground. Although you can connect that black wire to ground near the sender, it is preferred you ground it near the instrument cluster for more accuracy. You cannot test this wire for any specific signal at this point.
- ?? **Gear-Position Sender (red, black, yellow, green, 18ga):** This sender will have 4 wires coming off of it. All 4 wires should go to the instrument cluster, through the 4-pin connector. You cannot test these wires at this point.

With all the wires routed and labeled, take a few moments to organize them behind the dash, and bundle them with a couple nylon wire ties or tape. Since they are all labeled at the ends, you should not have to worry about which is which. Now, determine what length you want for the wires and cut them all to the same length. You should leave an extra foot or two outside the front of the dash so that you can remove the cluster easily and still have it connected/operating during setup.

## Indicators:

We will now focus on the indicators. For each indicator, you will need a single wire with an active-high signal (0V default, or +12V to turn on the indicator). You can re-use the same wires going to the original indicators, but test each one first to determine if the **signal** type is correct. If

any signal switches to 0V instead of 12V, you will need to connect these via a relay to reverse the switching. Label these wires as you test them. Once these are located, tested, and labelled, bundle them together with the other wires and cut them to the same length.

### Connector:

You will now need to connect the pins for the connector(s) on the ends of all the wires. This procedure is a bit time consuming, but not difficult and very important. Refer to the following diagram of a pin and wire:

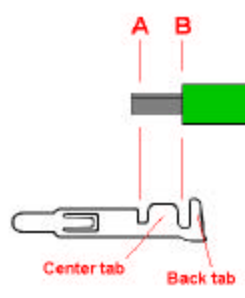

First strip the end of one of the wires to expose about a 1/4" of the wire. Then simply slip it into the slot at the back of the pin, ensuring that the exposed area goes at least as far forward (to the left in this diagram) as point A. The insulated part should go up to only as far as point B. Bend one side of the center tab over using a pair of needle-nose pliers, and squeeze it with the wire until it is secure. Then bend over the other side of the center tab and squeeze it until it is very tight. After this, bend over and squeeze one side of the back tab, squeeze it tight, then bend over the remaining back tab and squeeze it. Ensure both pairs of tabs are squeezed very tight, and it is highly recommended that the wire be soldered to the pin at this point. You should heat the area around the center tabs with the soldering iron, then let solder flow to the wire from point A. Don't build up too much solder around the outside of the pin as it will prevent the pin from slipping into the connector housing. Let the pin cool, but do not insert it into the connector housing yet.

Repeat this procedure for all the wires. Extra pins are provided in case any are dropped/lost or improperly crimped.

At this point, paying very careful attention to the pinout diagram supplied with your instrument cluster, insert the pins into the housing. The housing is polarized via a few flat surfaces as per this diagram:

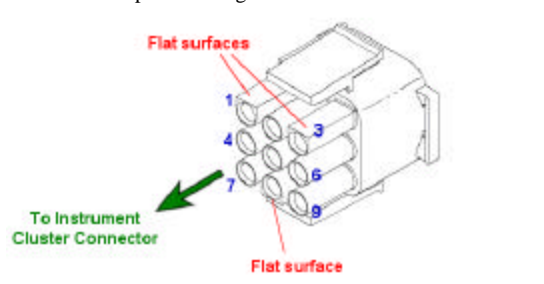

Pins numbers are also shown on the diagram in blue. These pins are not easily removeable without a special tool, so check and re-check each pin carefully prior to inserting them into the housing. When the pins is fully inserted into the housing, you will hear a click.

There will be one or more connectors based on the functions in your instrument cluster. Once all the pins are inserted, organize them with nylon wire ties, tape, and/or wire-loom. Also do this for any wires going to the various senders, and move wires away from any sources of high heat or protect them with thermal insulation.

## MOUNTING

### Remote wired switches:

If your instrument cluster is equipped with remote wired switches, mount the switch panel with a couple screws. A recommended location is under the dash near the steering column.

### Instrument cluster:

Unless otherwise noted, your instrument cluster will arrive assembled in the original instrument cluster housing, so mounting is a simple process. Plug in the connectors you wired up in the previous section, noting the polarity on the connectors. With the ignition key in the off position, reconnect the battery cable. Turn the ignition key on and the instrument cluster should come alive. If not, switch off the ignition key, unplug the connectors and re-test all the pins to locate the problem.

The service manual for the vehicle will show the procedure for installation of the instrument cluster, or simply reverse the removal process. For clusters that are not a drop-in replacement, secure the panel using the tabs and holes provided for this purpose. Care should be taken not to allow

any metal tabs or standoffs to bridge solder traces. Use threadlocker or nail-polish on screws to prevent loosening under vibration. If available, use rubber isolation mounts/studs.

## OPERATION

This is the fun part – setup of all the gauges. Although it can be a bit confusing at first, it is actually very simple once you understand the few basic concept of the switches. Simply put, each switch has 2 modes of operation – press and hold to change mode, or tap (press and release quickly) to change a value within any mode.

For remote wired switches, there will be one switch for each gauge.

If your instrument cluster is setup for an infrared remote control system, there are only 2 buttons on the keyfob controller. One of these selects the instrument being controlled, which is shown on a single-digit LED display on the instrument cluster. Usually this LED is off, but comes on when the select button is pressed on the keyfob. The LED goes off after about a minute of no activity. Once a gauge is selected, pressing the other button will function just as the regular control switch for just that gauge. Gauges are numbered starting in the upper left corner (#1), then downwards to #2, etc until the last gauge in the bottom right corner.

On each gauge, you can set brightness in 2 modes (lights off, lights on), some gauges have adjustable bargraph scales, and others have alarms which flash or beep (if your instrument cluster is setup for audible alarms). Specific modes available and setup instructions for each gauge are provided below. Only a few gauges require calibration, which should be done first. Later you can return to the setup procedure to setup options such as setting alarms, brightness, etc.

?? **Oil Pressure:** No calibration is necessary. Modes are as follows:

MODE	DISPLAY	SETTINGS
Normal	(Pressure)	
Set low-pressure alarm	L . 20	Sets the low-pressure alarm threshold in PSI.
Set high-pressure alarm	H . 70	Sets the high-pressure alarm threshold in PSI.
Brightness Regular	Br . 9	Last digit shows regular brightness level from 1 to 9.
Brightness park-lights on	BP . 1	Last digit shows brightness level with lights on from 1 to 9.

?? **Water Temperature:** No calibration is necessary. Modes are as follows:

MODE	DISPLAY	SETTINGS
Normal	(Temp)	
Set bargraph scale	250	250 => 140-250 deg scale, 285 => 120-285 deg scale, 320 => 100-320 deg scale
Set lo-temp alarm	L . 145	Sets the lo temp alarm level from 145-190 degrees. Use only for specific situations.
Set high-temp alarm	H . 200	Sets the high temp alarm threshold from 200-325 degrees.
Peak feature on/off	P . Of	Turns on of off the bargraph peak indicator feature. Tap during run to reset.
Brightness Regular	Br . 9	Last digit shows regular brightness level from 1 to 9.
Brightness park-lights on	BP . 1	Last digit shows brightness level with lights on from 1 to 9.

?? **Oil Temperature:** No calibration is necessary. Modes are as follows:

MODE	DISPLAY	SETTINGS
Normal	(Temp)	
Set bargraph scale	250	250 => 140-250 deg scale, 285 => 120-285 deg scale, 320 => 100-320 deg scale
Set lo-temp alarm	L . 145	Sets the lo temp alarm level from 145-190 degrees. Use only for specific situations.
Set high-temp alarm	H . 200	Sets the high temp alarm threshold from 200-325 degrees.
Peak feature on/off	P . Of	Turns on of off the bargraph peak indicator feature. Tap during run to reset.
Brightness Regular	Br . 9	Last digit shows regular brightness level from 1 to 9.
Brightness park-lights on	BP . 1	Last digit shows brightness level with lights on from 1 to 9.

?? **Transmission-Fluid Temperature:** No calibration is necessary. Modes are as follows:

MODE	DISPLAY	SETTINGS
Normal	(Temp)	
Set bargraph scale	250	250 => 140-250 deg scale, 285 => 120-285 deg scale, 320 => 100-320 deg scale
Set lo-temp alarm	L . 145	Sets the lo temp alarm level from 145-190 degrees. Use only for specific situations.
Set high-temp alarm	H . 200	Sets the high temp alarm threshold from 200-325 degrees.
Peak feature on/off	P . Of	Turns on of off the bargraph peak indicator feature. Tap during run to reset.
Brightness Regular	Br . 9	Last digit shows regular brightness level from 1 to 9.
Brightness park-lights on	BP . 1	Last digit shows brightness level with lights on from 1 to 9.

?? **Fuel-level:** Needs to be calibrated for empty level, full level and optionally, mid level. Since you usually won't be able to physically move the sender arm to set these levels, follow this procedure:

- **Full point:** First fill the tank completely, and drive normally for a while. When you estimate about a half-gallon to one gallon has been consumed, mark this as the full level.
- **Empty point:** Drive until the tank gets empty, and mark this as the empty level. You may want to carry a spare gallon of fuel in a portable container when getting to the empty level.
- **Mid-point:** Since fuel tanks are usually not linear from top to bottom, you may notice that the amount of miles you can travel from full to mid-level varies from the amount of miles you can travel from mid-level to empty. If this is the case, and the variation is enough to be an issue, you can compensate for this electronically by setting the mid point. First, determine how many miles you generally get on a full tank of fuel. Then the next time you fill up and drive half that amount, set the mid-point level. Modes are as follows:

MODE	DISPLAY	SETTINGS
Normal	(Fuel level)	
Brightness Regular	Br . 9	Last digit shows regular brightness level from 1 to 9.
Brightness park-lights on	BP . 1	Last digit shows brightness level with lights on from 1 to 9.
Set full level	FUL	Mark existing level as the full level.
Set mid fuel level	HLF	(Optional). Mark the current fuel level as mid-point level.
Set empty level	ETY	Mark the current fuel level as empty level.
Set low-fuel warning	L . 05	Sets the level (Off -40%, in 5% steps) at which the low-fuel warning will go on (blink).

- ?? **Speedometer:** You will need to calibrate this for correct speed reading since there will be many variables involved in this system such as speed sender type, gear ratios, tire sizes, etc. First, drive the vehicle at a known speed (either another vehicle next to you or a GPS will work), then mark the displayed speed and the known speed. To enter the calibration mode, switch to Set-Startup mode (shown in the table below), set the value to "Cal" (rather than "Run"), then power the unit off and back on using the ignition key. The first thing displayed is the existing calibration value. Calculate the new calibration value using this formula:

$$\text{New\_Calibration\_Setting} = \frac{\text{Existing\_Calibration\_Setting} \times \text{Known\_Speed}}{\text{Displayed\_Speed}}$$

At this point, change the calibration value to the new calculated value. Power off and on again to return to regular run mode. Modes are as follows:

MODE	DISPLAY	SETTINGS
Normal	(Speed+Odo) or (Speed+Trip)	Tap to change between odometer and trip. With odometer showing, press and hold to change modes (as listed below), OR with tripmeter showing, press and hold to reset tripmeter.
Set bargraph scale	S120	0-120 MPH, 0-180 MPH, 0-240 MPH
Peak feature on/off	P . Of	Turns on or off the bargraph peak indicator feature. Tap during run to reset.
Brightness Regular	Br . 9	Last digit shows regular brightness level from 1 to 9.
Brightness park-lights on	BP . 1	Last digit shows brightness level with lights on from 1 to 9.
Set startup mode	RUN-	Sets the mode in which the gauge will start on next power-up ("Run" or "Cal").

- ?? **Tachometer:** You will need to calibrate this for the number of engine cylinders. To enter the calibration mode, switch to Set-Startup mode (shown in the table below), set the value to "Cal" (rather than "Run"), then power the unit off and back on using the ignition key. The first thing displayed is the existing setting for number of cylinders. Tap the button until the correct number of cylinders is displayed, then power off and on again to return to regular run mode. Note that there are a few ignition systems that puts out a different number of ignition pulses than a typical distributor system, so the setting will need to be different than just the number of cylinders. Contact us for the proper setting in these cases. Modes are as follows:

MODE	DISPLAY	SETTINGS
Normal	(Engine RPM)	
Set bargraph scale	Sc 6	"6" => 0-6000 RPM, "9" => 0-9000 RPM, "12" => 0-12000 RPM
Peak feature on/off	P . Of	Turns on or off the bargraph peak indicator feature. Tap during run to reset.
Brightness Regular	Br . 9	Last digit shows regular brightness level from 1 to 9.
Brightness park-lights on	BP . 1	Last digit shows brightness level with lights on from 1 to 9.
Set startup mode	RUN-	Sets the mode in which the gauge will start on next power-up ("Run" or "Cal").

- ?? **Outside air temperature:** No calibration is necessary. Modes are as follows:

MODE	DISPLAY	SETTINGS
Normal	(Temp)	
Set bargraph scale	S96	Sets bargraph scale to 0-96 deg F, 0-120 deg F, or 0-216 deg F
Brightness Regular	Br . 9	Last digit shows regular brightness level from 1 to 9.
Brightness park-lights on	BP . 1	Last digit shows brightness level with lights on from 1 to 9.

- ?? **Gear-Position Indicator:** You will need to calibrate this unit for your specific gear positions. Start by pressing and holding the control button for a couple seconds until the first gear position starts flashing. Move the gear-shift level to the displayed/flashing gear

position, then tap the control button to mark that position. The next gear position will begin flashing on the display. Repeat for all the gears. The gear position indicator system may be setup for more gears than are actually available on your transmission, but you do not need to set all positions. When you are done, simply power off and power the unit back on.

### **FINAL TEST & USAGE**

This is it ... for now. Test all the gauge functions, and use the gauge display as you would any other set of instruments. Later, you can setup and use the other features such as alarms, brightness levels, peak feature, etc.

### **WARRANTY & LIABILITY**

Neither VEI Systems, nor its dealers or agents shall be liable in any way, for any damage, loss, injury or other claims, resulting from the installation or use of this product. By purchasing or installing this product, you assume all liability of any kind connected with the use and/or application of this product. If you are unsure that you can safely install and use this product, consult a qualified installer or mechanic. The warranty on this product covers only the product itself for a period of 1 year from the date of purchase, and it will be at our discretion to repair or replace the affected parts.